

X	0 ... +150
---	------------

U	0 ... 20	0 ... 39	0 ... 80
W	59 ± 3	78 ± 3	119 ± 3
	63	82	123

a	230 ... 360	
b	c-90	$\sqrt{a^2+(x+71)^2-90}$
dmin.	c+570	$\sqrt{a^2+(x+71)^2+570}$

gezeichnete Situation a = 360

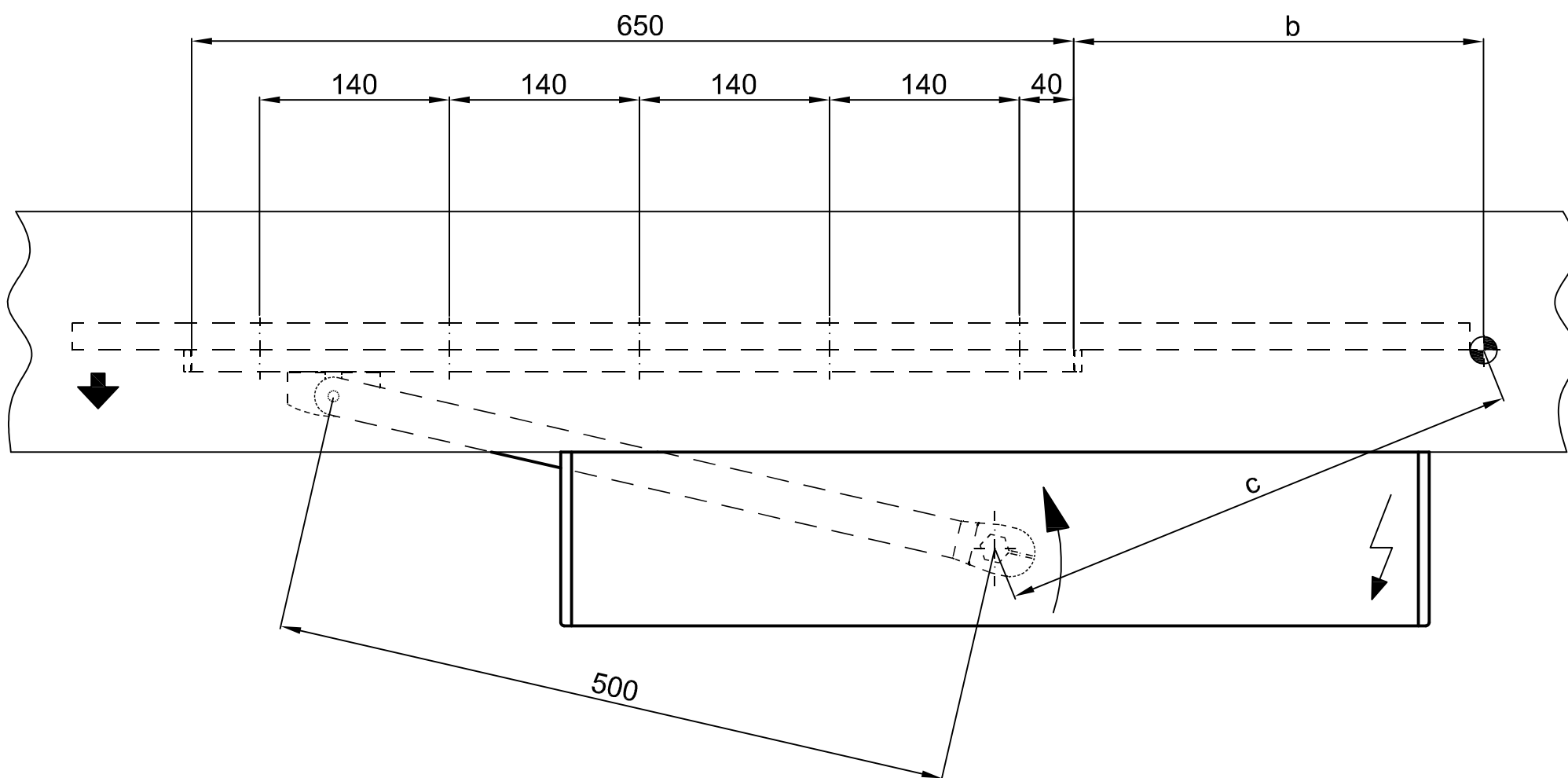

Objekt:				
Kunde:				
AuftragsNr.:		Datum:		Freigabevisum:
		Massstab	Gezeichnet	17.09.14
		%	Gut zum Druck	HOTH
Antriebstyp : Ausführung:				
TORMAX 1201   1102 Gleithebel 500mm/Sturzmontage				
 TORMAX ist eine Division und ein registriertes Markenzeichen der Landert Motoren AG, CH-8180 Bülach-Zürich			DokumentenNr.:	Index
			T3-386-78	.